



WONDERSUN

POWER CONNECTOR



Technical Characteristics

Materials and Finishes

Insulator: Glass-filled Nylon, UL 94V-0, Color:Black Standard.
(Consult factory for availability of other colors.)

Contacts: Precision machined copper alloy with gold flash over nickel. Other finishes available upon request.

Electrical Characteristics

Contact Current Rating (per UL 1977):
Size 8 Contacts: 60 amperes, continuous (standard material).
Consult factory for high conductivity material.

Initial Contact Resistance max. (per IEC 512-2, Test 2b):
Size 8 Contacts: 0.001 ohms (standard material).

Insulator Resistance (per IEC 512-2, Test 3a): 5 G ohms.

Voltage Proof: 2200 V r.m.s.
Working Voltage: 600 V r.m.s.
Hot Pluggable: Consult factory.

Mechanical Characteristics

Polarization: Provided by connector body design.

Removable Contacts: Insert contact in rear face of insulator; release from front face of insulator with a contact extraction tool. Female contacts feature "Closed Entry" design.

Removable Contact Retention in Connector Body: 67 N [15 lbs.] per IEC 512-8, Test 15a.

Mechanical Operations: 1,000 cycles

Climatic Characteristics

Working temperature: -55°C to +125°C

UL : Consult factory.
TÜV: Consult factory.

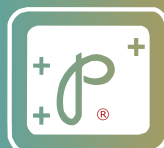

POSITRONIC

GLOBAL *Connector* SOLUTIONS

www.connectpositronic.com



Outline Dimensions

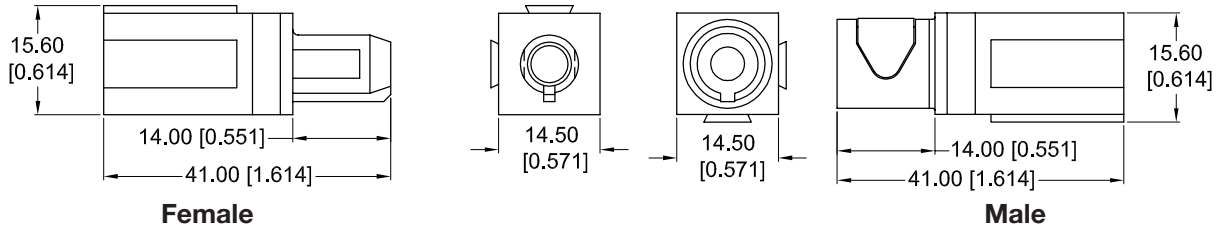

Temperature Rise Curves

Tested per IEC 512-3, Test 5a

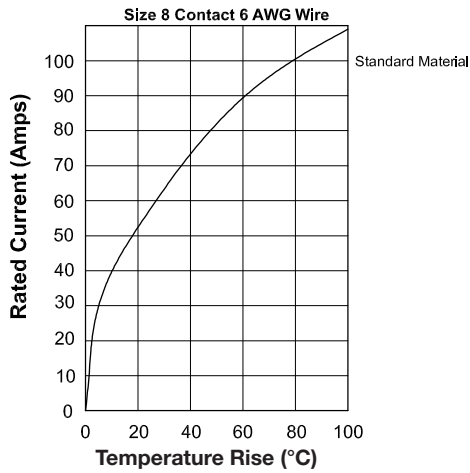

Above curves developed using Size 8 contact with 6 AWG wire.

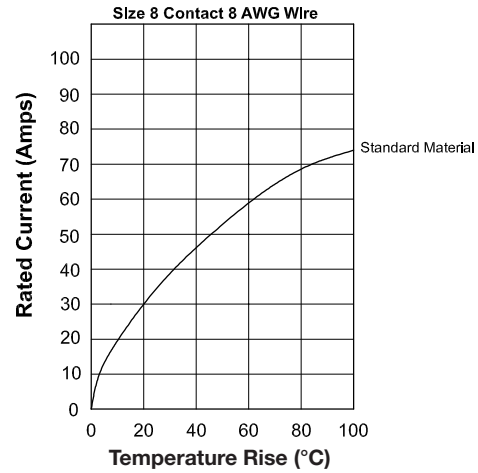

Above curves developed using Size 8 contact with 8 AWG wire.

Consult factory for high conductive contact material results.

Accessories & Contacts

Mounting Bracket

Plastic Mount Bracket for Single Connector

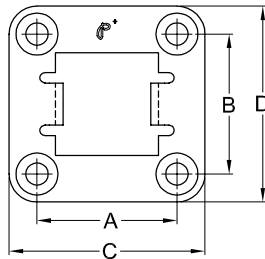

Materials and Finishes: PC UL 94V-0.
Thickness: 2.00 [0.079].

Metal Mount Brackets for Two Connectors

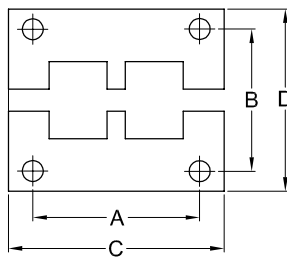

Materials and Finishes: Steel, Zinc Plate,
Thickness: 1.50 [0.059].

Panel Mount Cut Out Dimensions

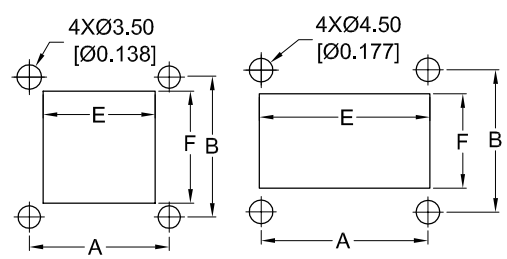

(Part number 5071-4-0 for metal mount plate, order separately)

Part No.	Description.	A	B	C	D	E	F
5071-12-*	Single Connector	20.00 [0.787]	20.00 [0.787]	28.00 [1.102]	28.00 [1.102]	16.00 [0.629]	16.00 [0.629]
5071-4-0	Two Connectors	31.80 [1.252]	27.10 [0.854]	41.50 [1.634]	35.20 [1.386]	32.50 [1.279]	18.00 [0.709]





Removable Crimp Contacts

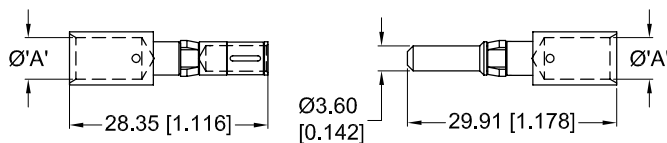

Part Number (Standard Material)	Wire Size AWG [mm ²]	ØA
Female Contacts		
WSFC86N2	6 [13.5]	5.92 [0.233]
WSFC88N2	8 [8.50]	4.60 [0.181]
Male Contacts		
WSMC86N	6 [13.5]	5.92 [0.233]
WSMC88N	8 [8.50]	4.60 [0.181]

Removable Internal Threads Contacts (Bus Bar Contacts)

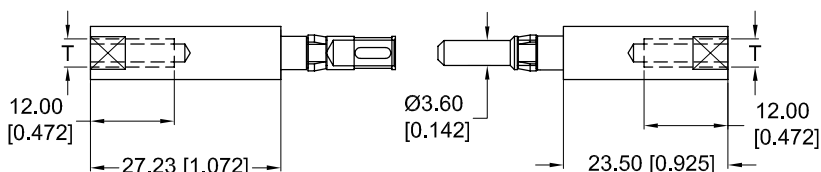

Part Number (Standard Material)	Thread T
Female Contacts	
WSFIT08M	M4 x0.7
WSFIT08S	8-32 UNC 2B
Male Contacts	
WSMIT08M	M4 x0.7
WSMIT08S	8-32 UNC 2B

Consult sales for availability of high conductivity material.

Multiple Connector Locking Feature

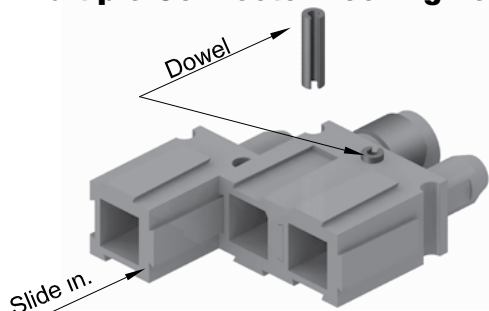

Connectors can be latched together via the built in attachment groove.
(Use dowel (part number 5071-13-0) for locking, order separately)
Material : Nylon, UL 94V-0

Polarization

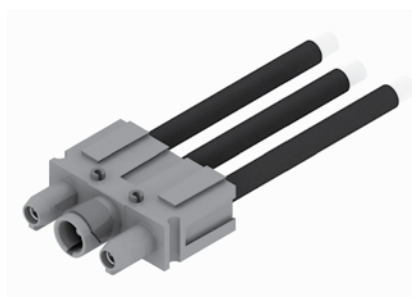

For multiple contact configurations, alternate male & female combination to avoid mismatching.

Locking Mechanism

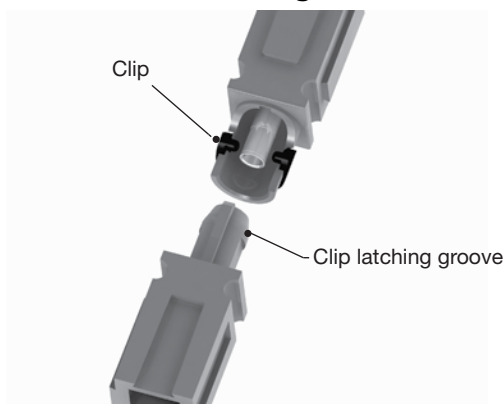

Color coding for easy mating

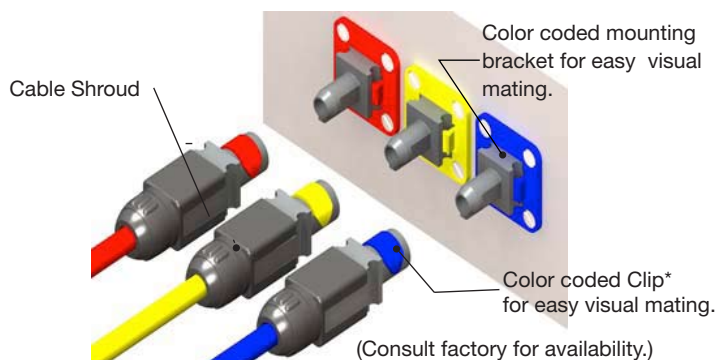

Cable Shroud

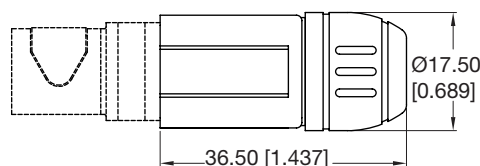
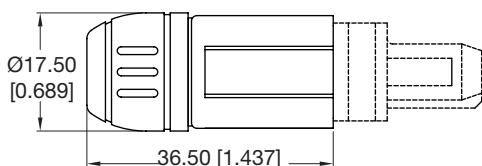

*Cable shroud will accept max. 7.00mm[0.275] diameter wire. Material : Nylon, UL 94V-0
(Consult factory for availability.)





Step	1	2	3	4	5	6
Example	WSS	01	M	P1	/AA	XXX
STEP 1: Basic Series WSS: Single Connector WSD: Two Connectors						STEP 6: Special Options Consult factory for color code Flange and Clip part numbers. (see page 3)
STEP 2: Type of Contacts 01 : Removable contact. Contacts ordered separately.						STEP 5: Environmental Compliance options /AA : Compliant per EU Directive 2002/95/EC (RoHS) Example: WSS01M0/AA Note: If no environmental options are required, this step will not be used. Example: WSS01M0
STEPS 3: Connector Gender M - Male F - Female				STEP 4: Mounting Style and Cable Shroud 0 : No hardware. P1 : Plastic panel mount bracket for one connector. (Select WSS in Step 1) J : Cable Shroud. (Mounting plate for two connector version order separately Part number 5071-4-0. see page 2 for details.)		

* Dowel required for multiple cable assembly see page 3 for details (order dowels separately)

Unless otherwise specified, dimensional tolerances are:

- 1) Male contact mating diameters : ± 0.03 [0.001]
- 2) Contact termination diameters : ± 0.08 [0.003]
- 3) All other diameters : ± 0.13 [0.005]
- 4) All other dimensions : ± 0.38 [0.015]

Dimensions are in millimeters [inches].
All dimensions are subject to change.

Recommended Tools for Removable Contacts

Contact Extraction Tool

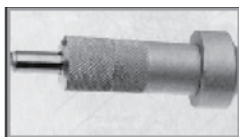

Adjustable Hand Crimp Tool

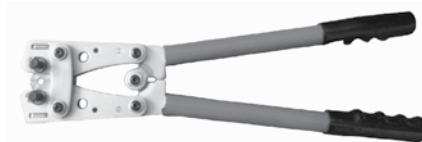

Positronic Recommended Conductor Tensile Strength (Pull Test)

To ensure proper crimp

Contact Size	Contact Extraction Tool	Hand Crimp Tool	Wire Size
Size 8	5071-100-0	5071-14-0	6 AWG [13.5 mm ²]
Size 8	5071-100-0	5071-14-0	8 AWG [8.5 mm ²]

Wire Size	Axial Load
6 AWG [13.5 mm ²]	1200N [270 lbs.]
8 AWG [8.5 mm ²]	890N [200 lbs.]

As per SAE AS39029

Positronic believes the data contained herein to be reliable. Since the technical information is given free of charge, the user employs such information at his own discretion and risk. Positronic assumes no responsibility for results obtained or damages incurred from use of such information in whole or in part.

POSITRONIC INDUSTRIES, INC.
423 N Campbell Ave, PO Box 8247
Springfield, MO 65801, USA
Telephone 1 417 866-2322
Fax 1 417 866-4115
info@connectpositronic.com

POSITRONIC INDUSTRIES, S.A.S.
Zone Industrielle d'Engachies
46 Route d'Engachies
France 32020 Auch Cedex 9
Telephone 33 (0) 5 6263 4491
Fax 33 (0) 5 6263 5117
contact@connectpositronic.com

POSITRONIC ASIA PTE LTD.
Blk 3014A
Ubi Road 1 #07-01
Singapore 408703
Telephone 65 6842 1419
Fax 65 6842 1421
singapore@connectpositronic.com