

SK4801

POSITRONIC INDUSTRIES BELIEVES THE DATA ON THIS DRAWING TO BE RELIABLE. SINCE THE TECHNICAL INFORMATION IS GIVEN FREE OF CHARGE, THE USER EMPLOYS SUCH INFORMATION AT HIS OWN DISCRETION AND RISK. POSITRONIC INDUSTRIES ASSUMES NO RESPONSIBILITY FOR RESULTS OBTAINED OR DAMAGES INCURRED FROM USE OF SUCH INFORMATION IN WHOLE OR IN PART.

DATE	REV	REVISION RECORD	APP	DR	CK
10-11-02	NC	ECO 20138		JLG	

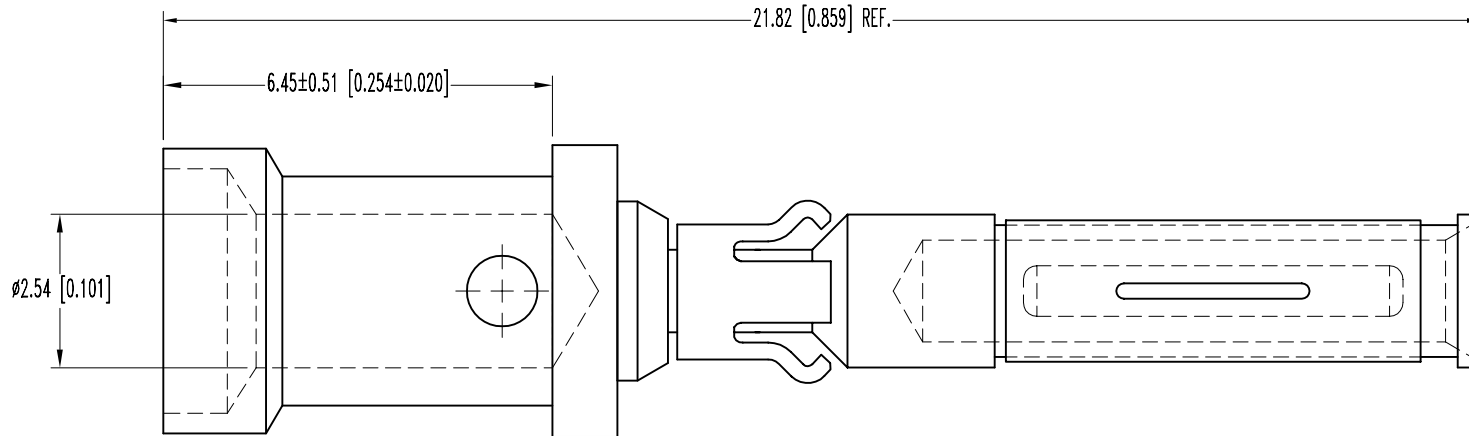

NOTES:

- MATERIAL AND FINISHES:
 CONTACT: COPPER ALLOY, GOLD FLASH OVER NICKEL.
 SPRING CLIP: BERYLLIUM COPPER, GOLD FLASH OVER NICKEL.
 RETAINER: BERYLLIUM COPPER, GOLD FLASH OVER NICKEL.
- USE CRIMP TOOL, PART NUMBER 9501-0-0 WITH POSITIONER 9502-19-0-0, FOR CRIMPING CONTACTS.
- USE REMOVAL TOOL, PART NUMBER 9081-4-0 FOR THE REMOVAL OF CONTACTS.
- DIMENSIONS ARE IN MILLIMETERS [INCHES].

 POSITRONIC INDUSTRIES INC. www.connectpositronic.com		SCALE N.T.S.		DRAWN BY J. GREEN	
DECIMAL TOL. ± 0.38 [0.015]		TITLE PLZ SERIES 12 AWG WIRE		APPROVED BY	
WF # 4879		FC112N2-381.0			
ANGULAR TOL. ± 5°		DATE 10-11-02		DRAWING NUMBER SK4801	
					REV. NC