

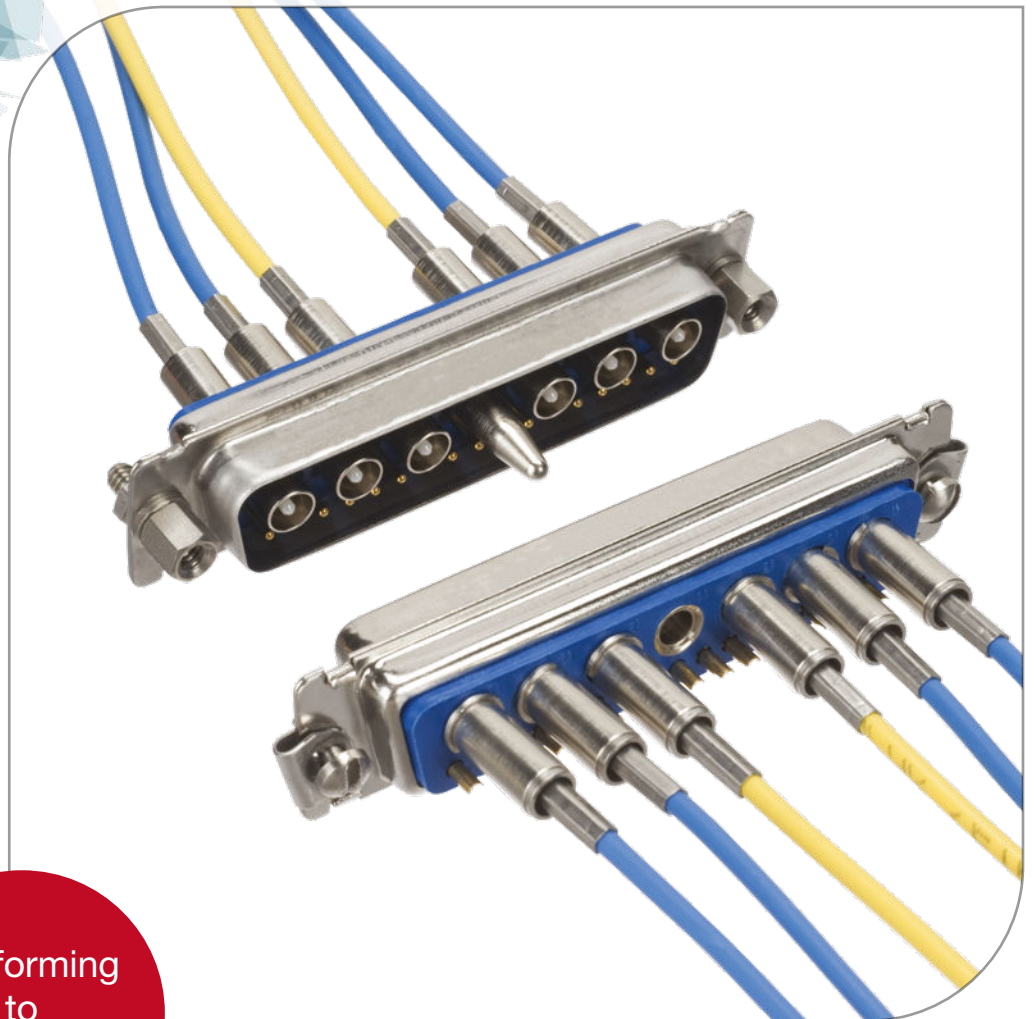

Positronic®

Low Loss Optical Interconnects for Harsh Environments
IL = 0.06 dB (typ)

Optik-D™ Series



Conforming
to
ARINC 801



OPTIK-D

TABLE OF CONTENTS

Introduction	02
Connector Anatomy	03
Technical Specifications	03
Exploded View	04
Guide Pin & Bushing	04
Terminus Detail	05
Dimensions	05
Tooling	06
Test Data	07
Part Number Definition	08
Cable Assemblies	10
Sales Offices	10



ACCOMPANYING CATALOGS

The Optik-D is intended for use in the Combo-D family of connector products. For a full understanding of this product family and its accessories, please reference the Combo-D and Accessories catalogs found at www.connectpositronic.com.

INTRODUCTION

Information in this catalog is proprietary to Positronic and its subsidiaries. Positronic believes the data contained herein to be reliable. Since the technical information is given free of charge, the user employs such information at his own discretion and risk. Positronic Industries assumes no responsibility for results obtained or damages incurred from use of such information in whole or in part.

The following trademarks are owned by Positronic Industries, Inc.: Positronic Industries, Inc.®, Positronic®, Connector Excellence®, P+ logo®, PosiBand®, PosiShop®, Positronic Global Connector Solutions™, Global Connector Solutions™ and Optik-D™. The color blue as it appears on various connectors is a trademark of Positronic Industries, Inc., Registered in U.S. Patent and Trademark Office.

DIMENSIONAL TOLERANCES

(unless otherwise specified)
 1) ± 0.13 [0.005] for all diameters
 2) ± 0.38 [0.015] for all other dimensions
 DIMENSIONS ARE IN MILLIMETER [INCHES].
 ALL DIMENSIONS ARE SUBJECT TO CHANGE.

The Positronic **FEDERAL SUPPLY CODE** (Cage Code) FOR MANUFACTURERS is **28198**

POSITRONIC® IS AN ITAR REGISTERED COMPANY

Products described within this catalog may be protected by the following US patent:
 #7,115,002 #8,944,697 #9,304,263

OTHER PATENTS PENDING

WHY FIBER?

- ✓ High bandwidth
- ✓ EMI immune
- ✓ Reduced wiring bulk and weight
- ✓ Improved data security
- ✓ Safe in explosive environments
- ✓ Minimal losses over long distances
- ✓ Eliminates ground loops
- ✓ Future proof applications



- MEDICAL IMAGING**
- AEROSPACE**
- OIL & GAS / MINING**
- TELECOM**

WHY OPTIK-D?

- ✓ Ultra low insertion loss of **0.06 dB** (typical) means **less optical power** is required, which can mean the difference between an inexpensive LED laser and a costly solid state laser
- ✓ Suitable for **harsh** environments
- ✓ More **cost effective** than D38999 and ARINC 600-based systems
- ✓ Wide availability of **accessories**
- ✓ **Compatible** with other ARINC 801 termini
- ✓ **Hybrid** connector allows for combination of optical, power, signal and/or coax in a single connector

CONNECTOR ANATOMY

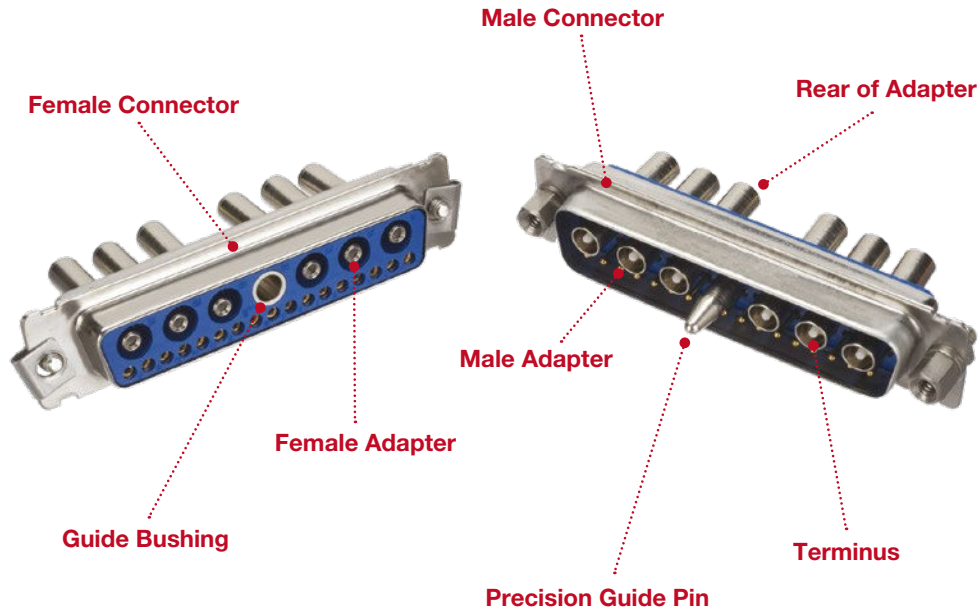

The low loss performance of this system is based on a **tight tolerance** guide pin and bushing that act jointly to keep the fiber cores **precisely aligned**.

The guide pins and bushings are installed at the factory and are required for proper performance.

TECHNICAL SPECIFICATIONS

Description	Value
Type	Multi-mode (Contact technical sales for single mode options)
Ferrule	1.25mm Zirconia Ceramic
Ferrule Holder	Brass alloy
Ferrule Holder Plating	Electroless nickel, 200 microinches
Rear Body & Crimp Sleeve	Corrosion resistant steel alloy
Passivation	Per SAE-AMS-QQ-PP-35 or ASTM-A-967
Cable Diameter	1.6 to 2.8 [0.065 to 0.110]
End Face Geometry	Meets Telcordia GR-326
Insertion Loss (IL)	0.06 dB (typical)
Minimum Loss	0.004 dB
Maximum Loss	0.08 dB
Return Loss (RL)	> 45 dB
Minimum Return Loss	> 45 dB
Temperature Range	-55° to 125°C
Locking System	Jackscrews (required)
Plastic Optical Fiber (POF)	The current Optik-D terminus is intended for glass fiber only. For high volume applications, a POF terminus can be provided. Contact technical sales for more information.
Cable Compatibility	Loose jacketed (pull-proof), 1.6mm to 2.8mm [0.065" to 0.110"] \varnothing Contact technical sales for details regarding tight jacketed and 900 μ m cable use

Pull-proof termini allow for the use of the connector without a backshell.

EXPLODED VIEW

During the terminus installation process, ensure that the terminus key is aligned with the keyway on the adapter and that the terminus is not rotated during installation.

Although not shown in this view, jackscrews are required for proper performance.

All items shown here except the termini are installed at the factory prior to shipment.

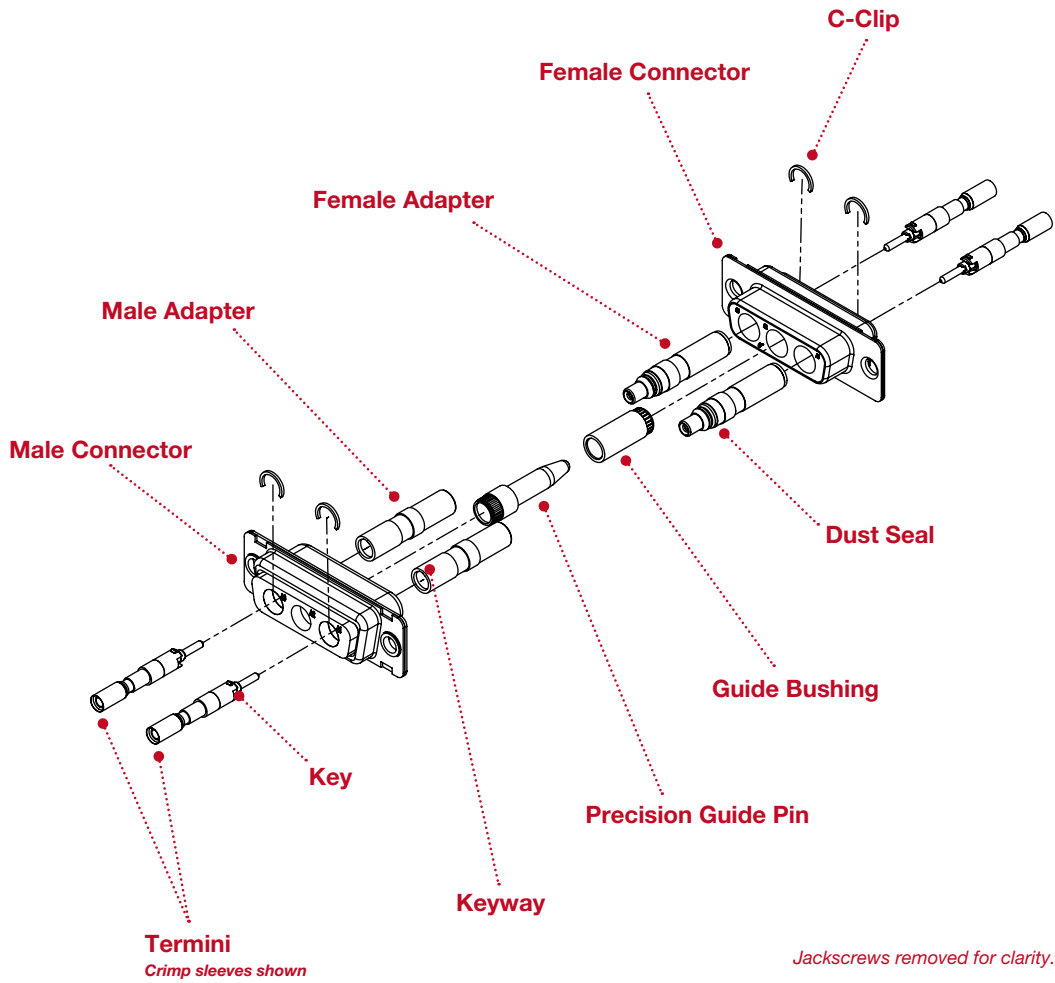

GUIDE PIN & BUSHING

Guide pins and bushings are mandatory for proper performance and occupy a size 8 contact position as shown here.

The guide pin is installed on the male connector and the bushing is installed on the female connector.

Contact technical sales for options to have the guide pin and bushing installed in a different location.

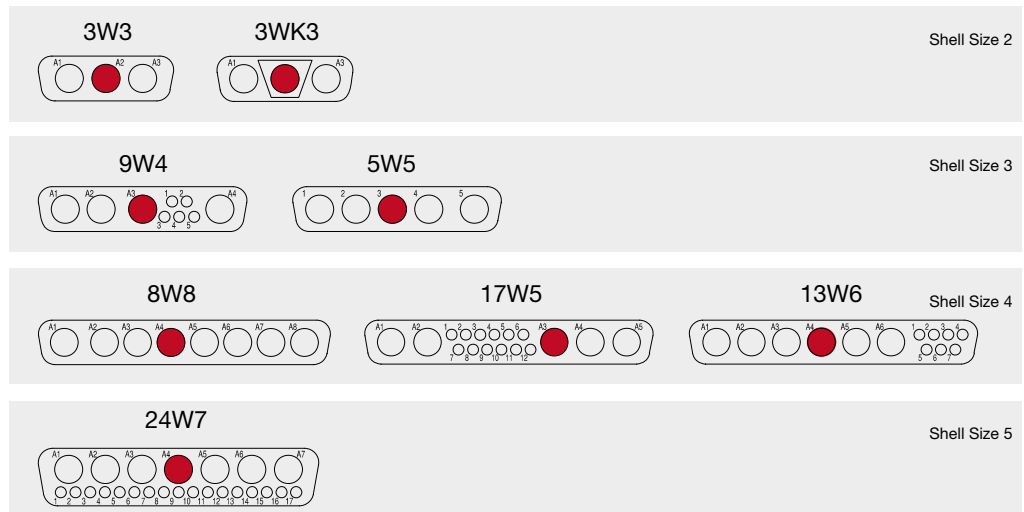

Red circle indicates location of guide pin or bushing.

TERMINUS DETAIL

The terminus design includes a key that aligns with a corresponding **keyway** in the rear body of the **adapter**.

Each terminus ships with a factory-installed **dust cover** and a crimp sleeve.

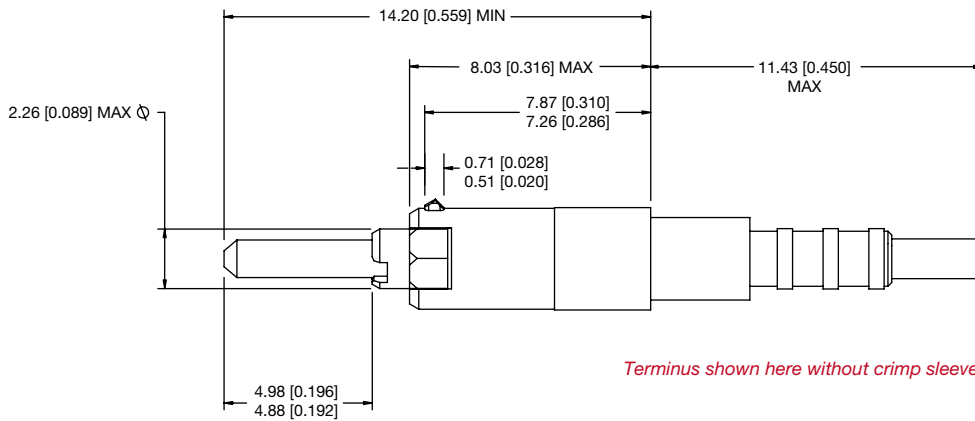

Terminus shown here without crimp sleeve.

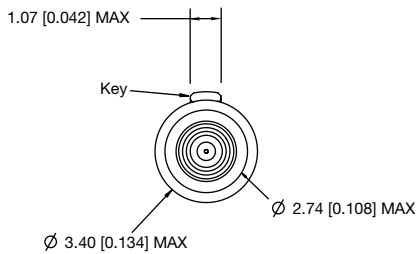

Part Number	Ferrule Diameter	Mode	Style
OT1260LMX/AA	126.0 μm	Multi-mode	Pull-proof

Contact technical sales for other types of available termini including those with alternate ferrule diameters and those intended for use with non-pull-proof cable.



OT1260LMX/AA
Crimp sleeve not shown

DIMENSIONS

Shell Dimensions

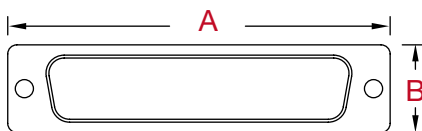

Shell Size	Connector Variants	A ± 0.38	B ± 0.38
2	3W3	39.14	12.55
	3WK3	[1.541]	[0.494]
3	5W5	53.04	12.55
	9W4	[2.088]	[0.494]
4	17W5	69.32	12.55
	13W6	[2.729]	[0.494]
	8W8		
5	24W7	66.93 [2.635]	15.37 [0.605]

For all related shell dimensions, please consult the **Combo-D** catalog, C-004.

Assembly Dimensions in Mated Condition

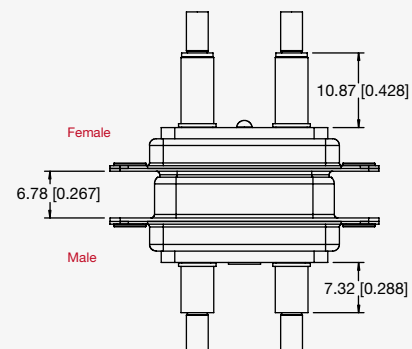

Jackscrews removed for clarity. All dimensions nominal.



TEST DATA

Testing performed at Exporior Laboratories in Oxnard, CA

TEST	TEST CONDITION	GROUP A ENVIRONMENTAL	GROUP B MECHANICAL PART 1	GROUP C MECHANICAL PART 2	GROUP D MATING ABILITY	REQUIREMENT	RESULTS	VALUE (dB) Typical
Attenuation & Splicing	TIA/EIA-455-171A	x	x	x	x	IL = 0.30 dB Max	Pass	0.06
Return Loss	TIA/EIA-455-107A	x	x	x		RL = 20 dB Min	Pass	> 45
Thermal Cycling	TIA-455-3B	x				CIT = ± 0.5 dB Visual Inspection	Pass	-0.02
Humidity	MIL-DTL-24308G EIA-364-31B Method IV	x				CIT = ± 0.5 dB Visual Inspection	Pass	-0.02
Temperature Life	TIA/EIA-455-4C	x				CIT = ± 0.5 dB Visual Inspection	Pass	0.05
Salt Spray	MIL-DTL-24308G EIA-364-26B Condition B	x				CIT = ± 0.5 dB Visual Inspection	Pass	-0.04
Thermal Shock	MIL-DTL-24308G EIA-364-32F Method A Condition 1	x				CIT = ± 0.5 dB Visual Inspection	Pass	-0.01
Vibration	MIL-DTL-24308G EIA-364-28F Condition IV		x			CIT = ± 0.5 dB Visual Inspection Discontinuity Test	Pass	-0.01
Shock	MIL-DTL-24308G EIA-364-27C Condition E		x			CIT = ± 0.5 dB Visual Inspection Discontinuity Test	Pass	-0.01
Maintenance Aging	EIA-364-24B			x		Insertion Force = 8 lbs Max	Pass	n/a
Mating Durability	MIL-DTL-24308G EIA-364-09C			x		CIT = ± 0.5 dB Visual Inspection	Pass	0.01
Cable Pull-Out	TIA-455-6B Method 1			x		CIT = ± 0.5 dB Visual Inspection Pull Force = 53.4 N for 5 sec	Pass	0.01
Termini Retention Force	EIA-364-38C Method A			x		Pull Force = 53.4 N for 1 hour Visual Inspection	Pass	n/a
Return Loss	TIA/EIA-455-107A	x	x	x	x	RL = 20 dB Min	Pass	> 45

- Test conditions were modified in some cases where the original test condition exceeded the performance limitations of the connector or termini. A full test report is available upon request.
- In order to pass the test plan requirements, the optical discontinuity could not exceed 1 μsec.
- Testing performed at 1300 nm.

PART NUMBER DEFINITION

Specify a part number by selecting an option from each step.

STEP	1	2	3	4	5
Example	CBF	5W5	F	0	0
STEP 1 - SERIES					
CBF – Optik-D Series					
STEP 2 - CONNECTOR VARIANTS - Face view of male or rear view of female					
Shell Size 2	3W3	3WK3			
Shell Size 3	5W5	9W4			
Shell Size 4	17W5	13W6	8W8		
Shell Size 5	24W7				
STEP 3 - CONNECTOR GENDER					
M – Male					
F – Female, open entry signal contacts (if applicable), use with 3W3, 3WK3, 5W5 or 8W8.					
S – Female, PosiBand closed entry signal contacts (if applicable), not for use with 3W3, 3WK3, 5W5 or 8W8.					
STEP 4 - ELECTRICAL CONTACT TERMINATION TYPE (IF APPLICABLE)					
0 - Use with 3W3, 3WK3, 5W5 or 8W8, order termini separately (see page 5).					
*1 1 - Crimp, signal 0.5mm ² [20 AWG], uses CBC Series step molding. Currently not tooled in 17W5 (male or female) or 13W6 (male).					
*1 2 - Solder cup.					
*1 4 - Solder tail, right angle (90°) PCB with 11.43 [0.450] contact extension.					
*1 5 - Solder tail, right angle (90°) PCB with 7.19 [0.283] contact extension.					
*1 59 - Solder tail, right angle (90°) PCB with 13.84 [0.545] contact extension.					
*1 Not for use with 3W3, 3WK3, 5W5 or 8W8.					
STEP 5 - MOUNTING STYLE					
0 - Mounting Hole, Ø 3.05 [0.120].					
*2 R2 - Bracket, mounting, right angle (90°) metal, swaged to connector with 4-40 thread fixed female jackscrews and alignment bar.					
*2 R6 - Bracket, mounting, right angle (90°) metal, swaged to connector with 0.120 [3.05] Ø mounting hole and alignment bar.					
*2 R7 - Bracket, mounting, right angle (90°) metal, swaged to connector with 4-40 threads and alignment bar.					
*2 R8 - Bracket, mounting, right angle (90°) metal, swaged to connector with 4-40 locknut and alignment bar.					
S5 - Swaged locknut, 4-40 threads					
*2 Not for use with Code 0, 1 or 2 in Step 4.					

Typical Multi-mode Fiber Anatomy

Many optical cables also have strength members between the jacket and the buffer for greater durability.

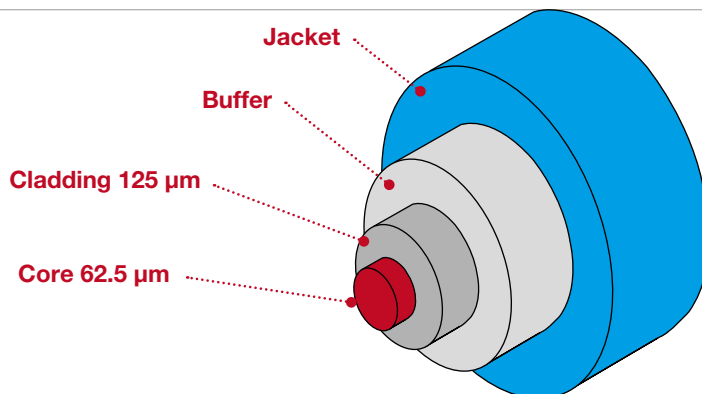

6	7	8	9	10
0	T2	S	/AA	
				<p>STEP 10 - SELECTIVE LOADING</p> <p>Use this step to specify which size 8 positions will NOT be populated with optical termini.</p> <p><i>I.E. CBF8W8M00ANES-A1A8 would yield an 8W8 with positions A1 and A8 empty so that electrical size 8 contacts can be used in those positions.</i></p>
				<p>STEP 9 - ENVIRONMENTAL COMPLIANCE OPTIONS</p> <p>/AA - RoHS Compliant</p> <p><i>An RoHS compliant connector with stainless steel shells will also have stainless steel hardware (backshell not included).</i></p>
				<p>STEP 8 - SHELL OPTIONS</p> <p>0 - Zinc plated. S - Stainless steel, passivated. X - Tin plated. Z - Tin plated and dimpled (male connectors only).</p>
				<p>STEP 7 - JACKSCREW LOCKING SYSTEMS</p> <p>0 - Available only when using 'Y' or 'Z' backshell in Step 6. T2 - Fixed Female Jackscrews. E - Rotating Male Jackscrews. Available only with AN backshell in Step 6. E2 - Rotating Male Screw Locks.</p>
				<p>STEP 6 - BACKSHELLS AND ADDITIONAL ACCESSORIES</p> <p>0 - None Y - Backshell, top opening, plastic with rotating male jackscrews. Available in shell size 5 only. Z - Backshell, top and side opening, robust and extended height, plastic with rotating male jackscrews. H - Backshell, top opening, metal. AN - Backshell, lightweight aluminum, nickel finish. N - Push-on fastener for right angle (90°) mounting brackets.</p>

Gore-Tex® gasket tape can be used as a protective layer between the fiber and the backshell cable clamp to prevent chafing.

2D DRAWINGS & 3D MODELS

Once you have made a connector selection, contact us if you would like a 3D model or 2D drawing. If the drawing does not already exist in our database, we can create one for you. We also have a variety of drawings available from our web site, www.connectpositronic.com.

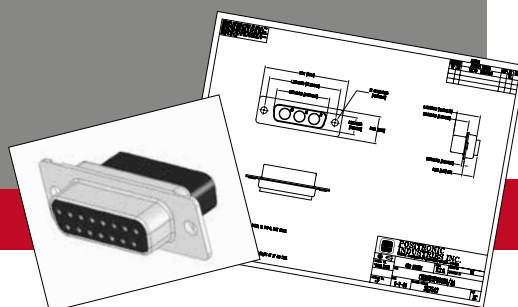

TOOLING

Contact technical sales regarding availability of an LC adapter that allows for use of industry standard LC tooling for termination, inspection and cleaning purposes of the ARINC 801 optical terminus.

This prevents from having to purchase and manage multiple sets of tooling if customers already own LC tooling.

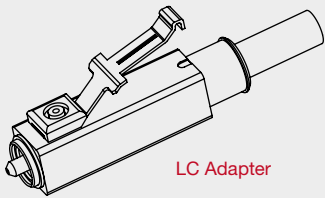

LC Adapter

ARINC 801 Termination Kits

This kit contains all of the tools and consumables required for terminating ARINC 801 termini.

Includes:

- Epoxy curing oven
- 200X handheld microscope
- Front epoxy injection tool
- ARINC 801 crimp tool with die set
- ARINC 801 polishing puck
- FiberSure multi-purpose optical strip tool
- Kevlar shears
- Carbide scribe tool
- ARINC 801 oven cure adapters
- ARINC 801 insertion and removal tools
- Tweezers
- Permanent marker
- Metal 6-inch ruler
- Optical cleaning fluid
- Optical cleaning wipes
- Epo-Tek 353ND epoxy
- All necessary polishing films
- Debris container



Kitco part number: 0741-8002

ARINC 801 Inspection & Cleaning Kits

Designed with input from the commercial air transport industry, this kit is intended to inspect and clean ARINC 801 fiber optic connectors found onboard the aircraft.

Includes:

- HD-2 display with video probe
- 1.25mm visual fault locator
- ARINC 801 cleaning sticks
- ARINC 801 cleaning tool
- Fiber optic cleaning wipes
- Fiber optic grade cleaning fluid
- Video probe tips for ARINC 801 and 1.25mm



Kitco part number: 0741-8012

ARINC 801 End Face Cleaning Tool

US Conec IBC brand cleaners use a novel dry cleaning strand to gently sweep and lift away contaminants from the end face including:

- | | |
|-------------------------|--------------------|
| Arizona road dust | Graphite |
| Alcohol residue | Salt water residue |
| Distilled water residue | Hand lotion |
| Skin oil residue | T-shirt lint |
| Vegetable residue | |



US Conec H125 part number: 12910

Insertion / Removal Tool

The Optik-D Series uses a widely available plastic tool for the insertion and removal of the terminus from the adapter.



Mil-spec part number: M81969/14-03



Cable Assembly Options

Positronic leverages its experience in high reliability connector manufacturing to build cable assemblies held to high standards. The cable assembly facility is certified to ISO9001 and AS9100. Contact Positronic for your optical cable needs.

Capabilities include:

- Design, development, engineering support and documentation
- Build-to-print
- Product prototyping and first articles
- Testing
- Adherence to IPC-620 standards

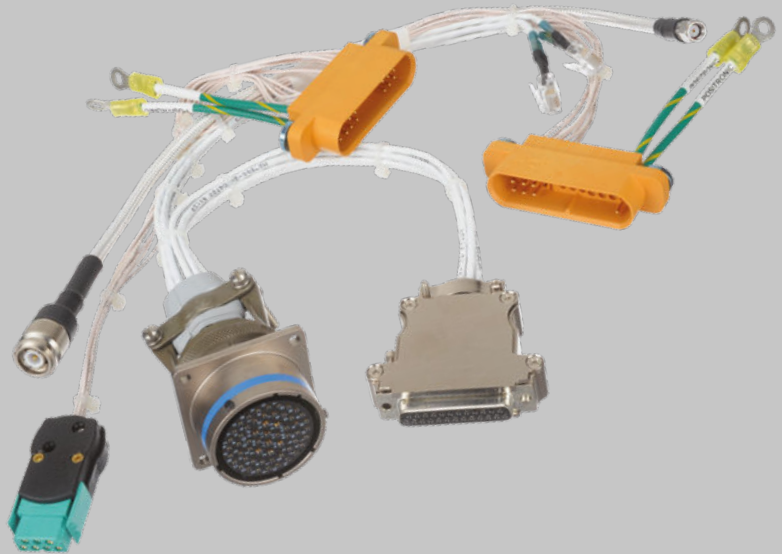
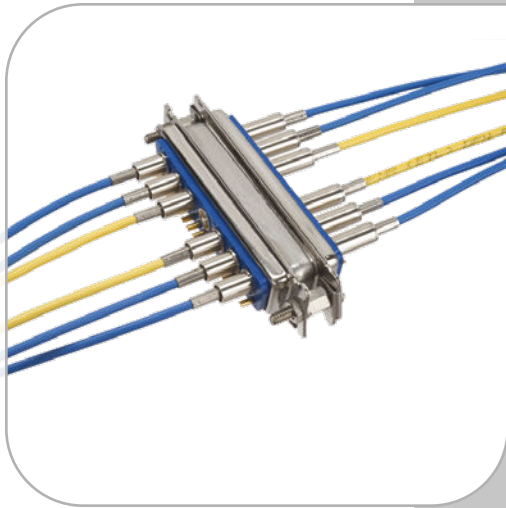

Regional Headquarters

Global Headquarters

Positronic | Americas

423 N Campbell Ave
Springfield MO 65806 USA

+1 800 641 4054
info@connectpositronic.com

European Headquarters

Positronic | Europe

Z.I. d'Engachies
46, route d'Engachies
F-32020 Auch Cedex 9 France

+33 5 6263 4491
contact@connectpositronic.com

Asian Headquarters

Positronic | Asia

3014A Ubi Rd 1 #07-01
Singapore 408703

+65 6842 1419
singapore@connectpositronic.com

Sales Offices

Positronic has local sales representation all over the world. To find the nearest sales office, please visit www.connectpositronic.com/sales